

Glider



EPOXIA

design:
Gianantonio Perin
Giorgio Topan

**Glider, Loopy e Take-Off. Tre espressioni di design,
tre modi di vivere l'ufficio operativo moderno.**

Glider, Loopy and Take-Off. Three design lines,
three ways of experiencing the modern office.

Glider, Loopy et Take-Off. Trois expressions de design,
trois façons de découvrir le bureau opérationnel moderne.

Glider, Loopy und Take-Off. Drei Designausdrücke,
drei Möglichkeiten, das moderne operative Büro zu erleben.

Glider, Loopy y Take-Off. Tres expresiones de diseño,
tres formas de vivir la oficina operativa moderna.

Loopy

Glider

Take-Off





Glider



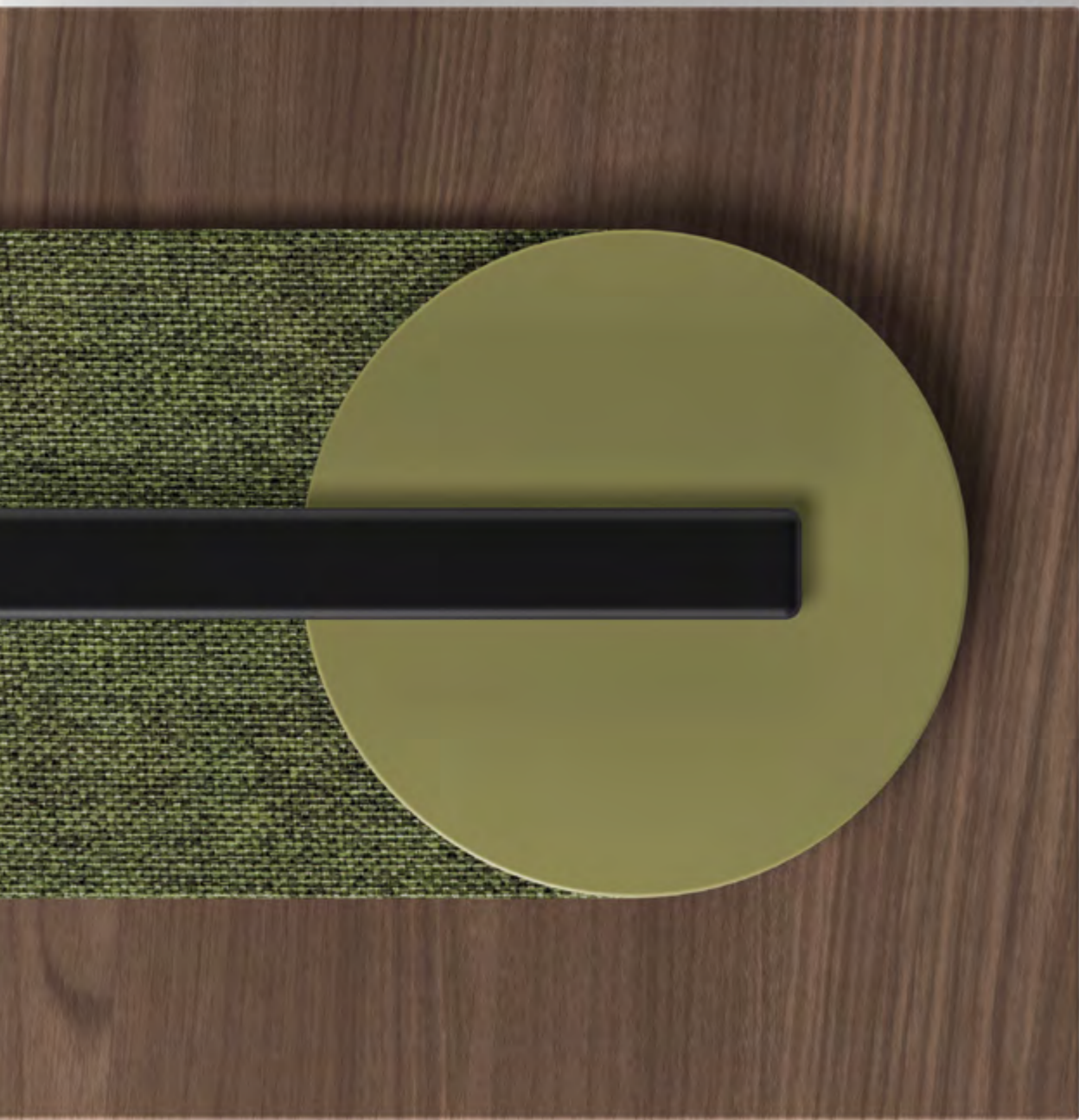

Design essenziale e personalizzazione delle finiture, così Glider rende accoglienti gli spazi di lavoro. Immersi nel bello si lavora di più e meglio.

Essential design and customization of finishes, so Glider makes workspaces welcoming. Immersed in beauty, you work more and better!

Design essentiel et personnalisation des finitions, Glider rend les espaces de travail accueillants. Immérgé dans la beauté, vous travaillez plus fort et mieux.

Minimalistisches Design und individuelle Gestaltung der Oberflächen, so macht Glider Arbeitsplätzen einladend. Eingetaucht in Schönheit, werden Sie noch gerne und besser arbeiten.

Diseño esencial y personalización de acabados, así Glider hace que los espacios de trabajo sean acogedores. Inmerso en la belleza se trabaja más y mejor.





Office e home office. In un contesto lavorativo ibrido, gli spazi diventano flessibili e gli arredi versatili, come il sistema Glider.

Office and home office. In a hybrid working context, spaces become flexible as furnishings, like Glider system.

Bureau et homeoffice. Dans un contexte de travail hybride, les espaces deviennent flexibles, et des meubles polyvalents, comme dans le système Glider.

Büro und Homeoffice. Innerhalb einem hybriden Ambiente werden die Büro-Räume flexibel und vielseitige Einrichtungen dank an das Glider Serie.

Oficina y oficina en casa. En un contexto de trabajo híbrido, los espacios se vuelven flexibles y los muebles versátiles como el sistema Glider.





Glider

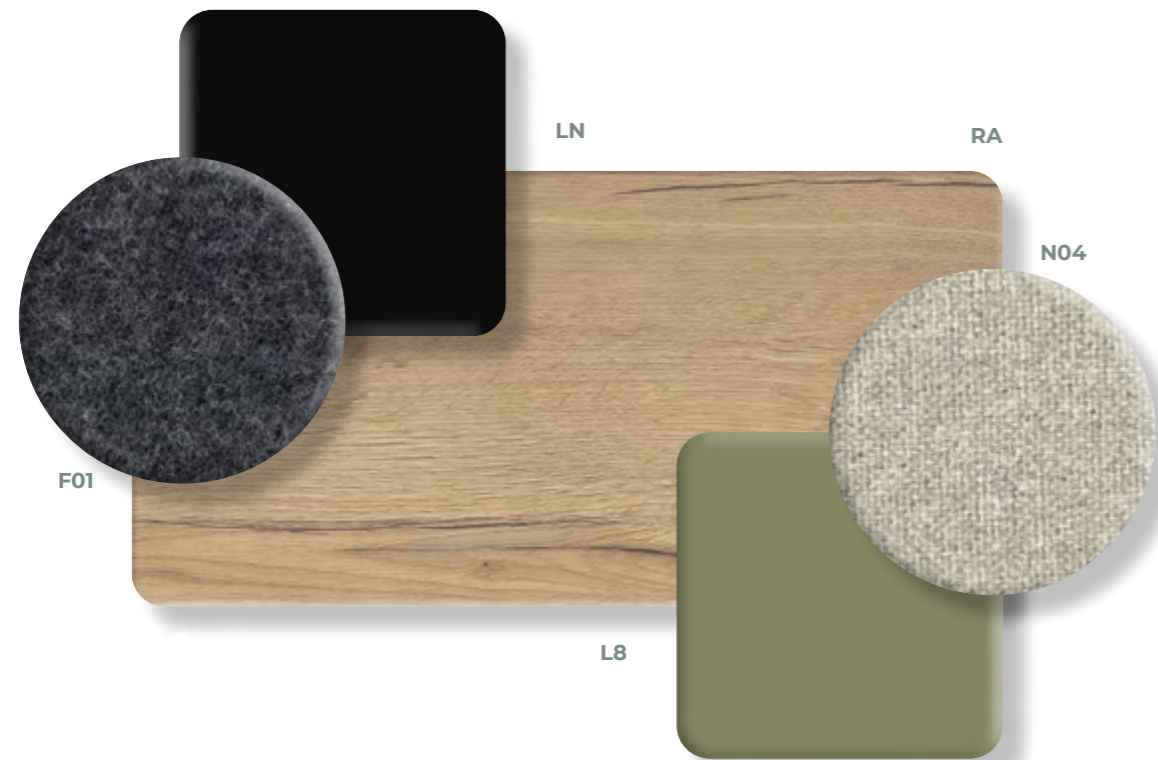
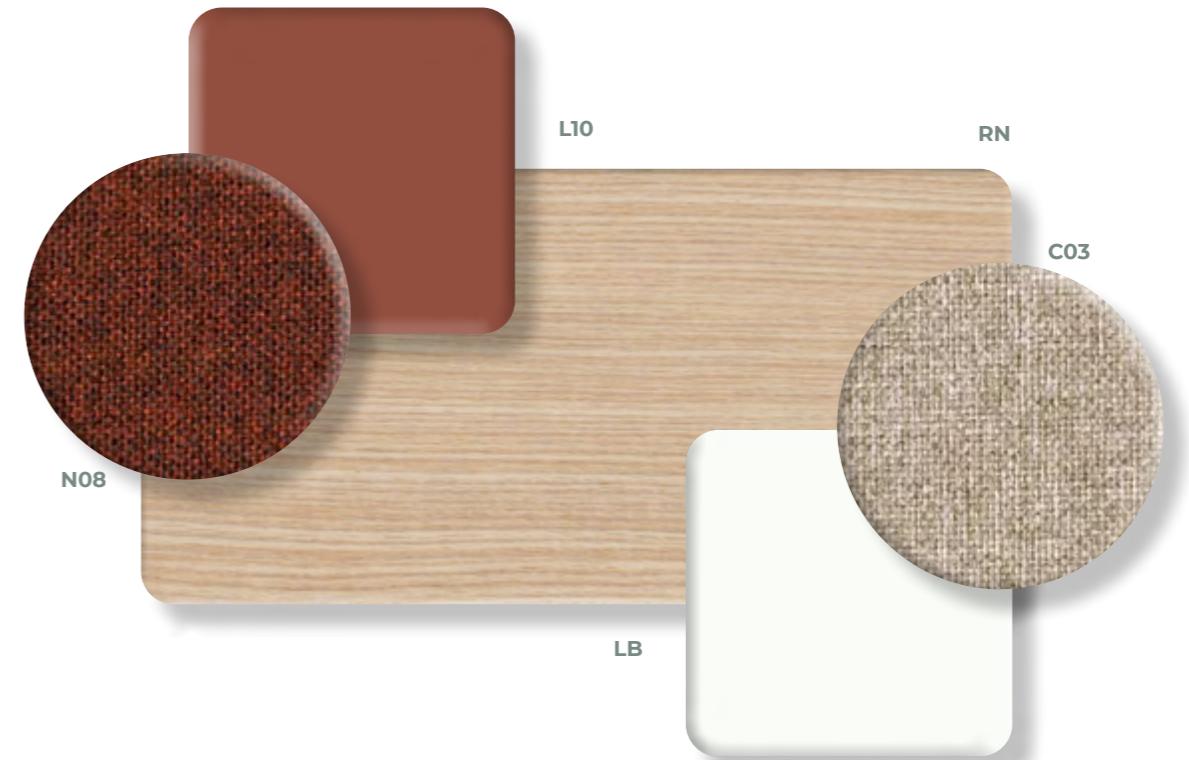
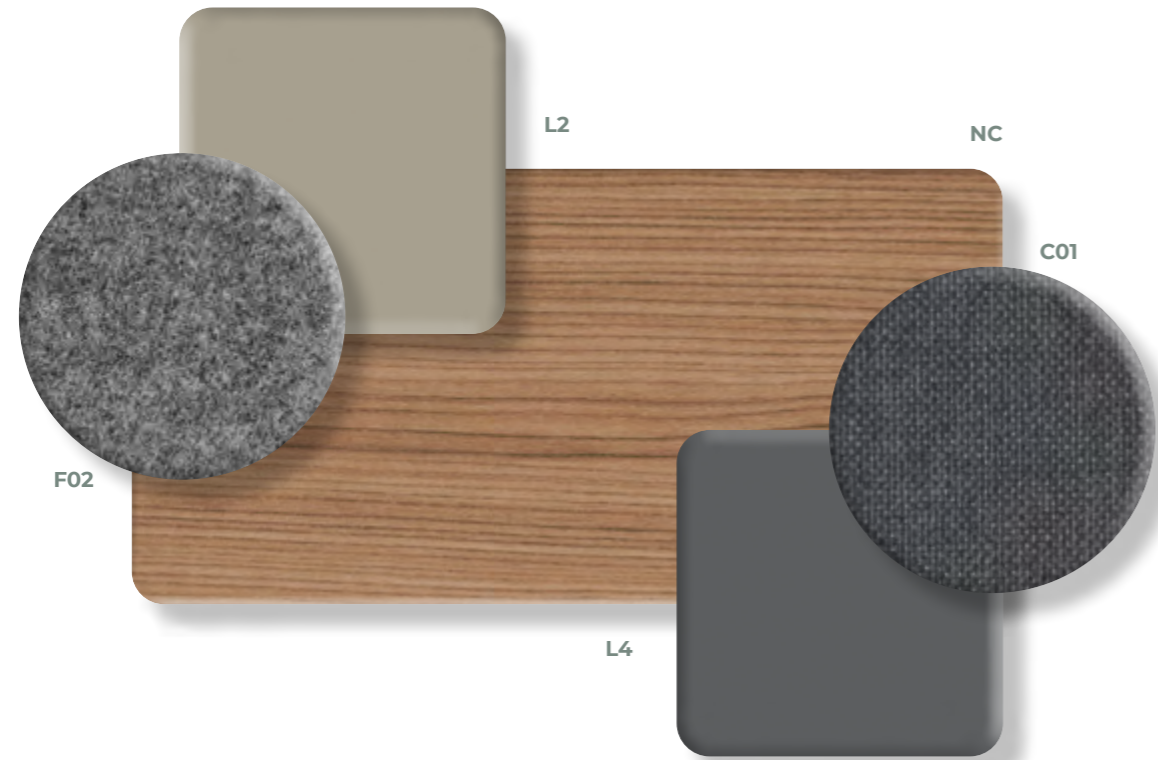



Glider



h 74 cm

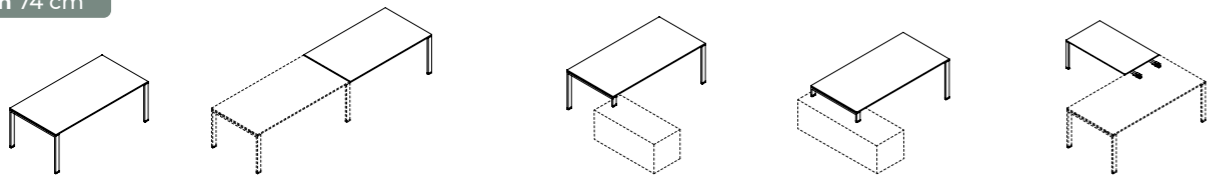

w 80÷200 cm
d 60-80 cm

w 200 cm
d 100 cm

w 160÷200 cm
d 80 cm

w 200 cm
d 100 cm

w 80-120 cm
d 60 cm

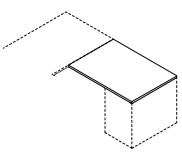

w 100-120 cm
d 60 cm

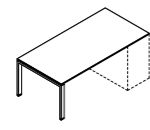

w 120-200 cm
d 60-80 cm

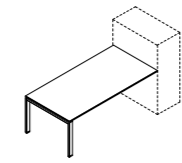

w 120÷200 cm
d 80 cm

h 74 cm

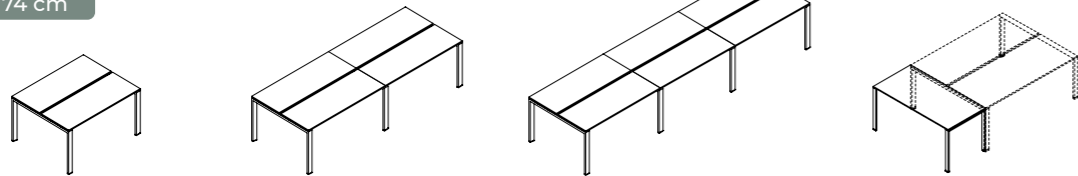

w 120÷200 cm
d 124-164 cm

w 240÷400 cm
d 124-164 cm

w 360÷600 cm
d 124-164 cm

w 124 w 164 cm
d 60 w 80 cm

h 74 cm

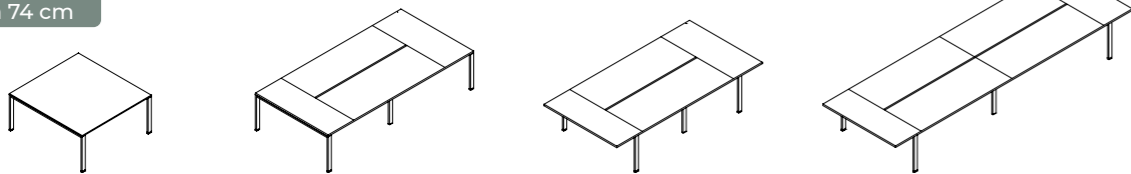

w 100÷240 cm
d 124-164 cm

w 280-320 cm
d 124-164 cm

w 240-320 cm
d 124-164 cm

w 360-520 cm
d 124-164 cm



h 38 cm

h 42 cm

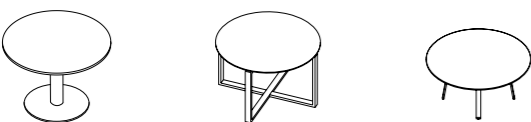

∅ 110-118 cm

∅ 118 cm

∅ 118 cm



w 60-120 cm
d 60 cm

w 60-120 cm
d 60 cm

Electrification

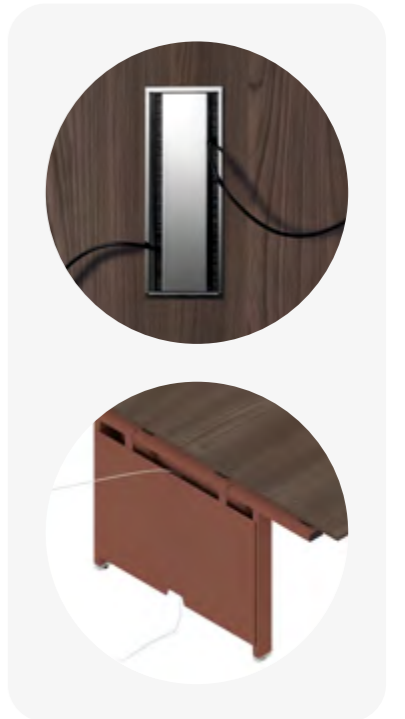
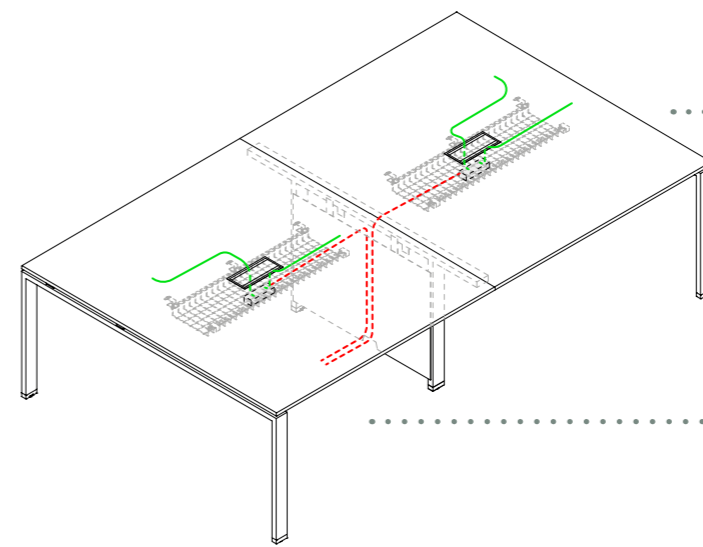
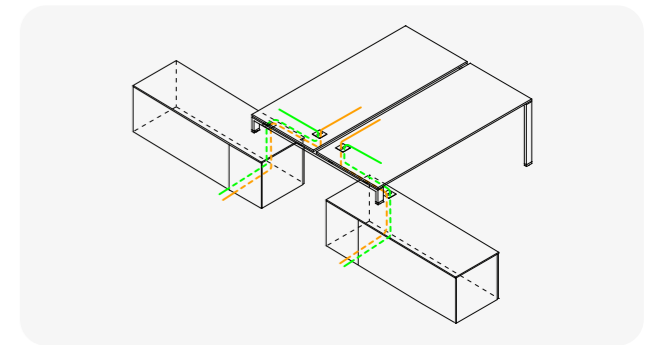
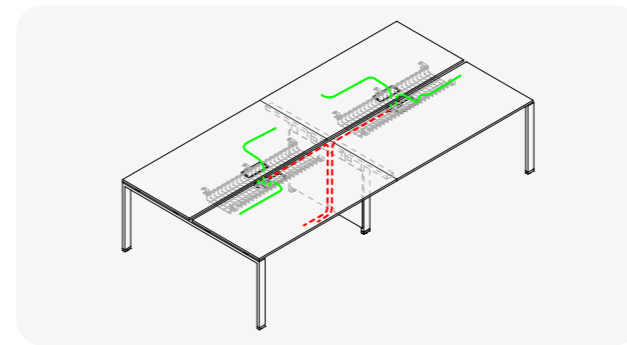
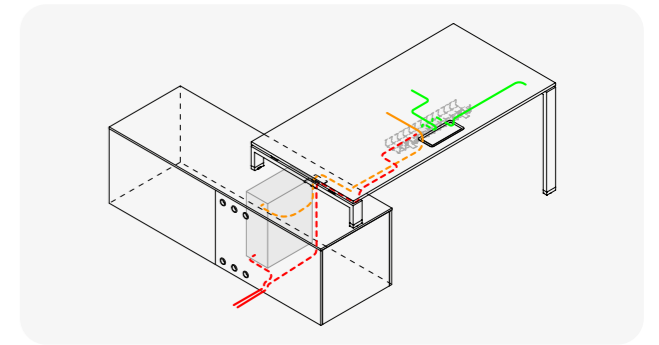
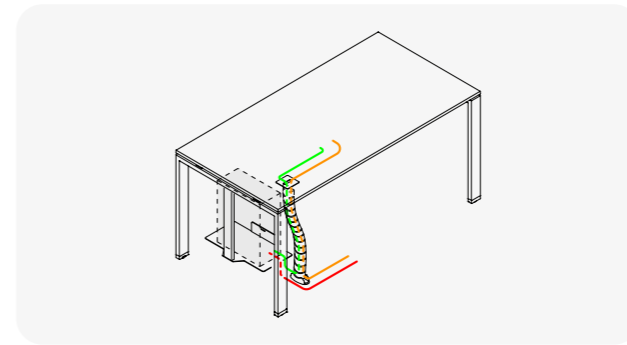

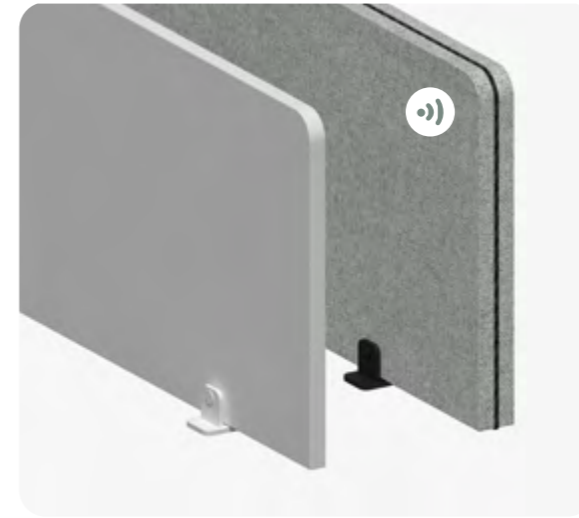



h 62 ÷ 86 cm

Regolazione in altezza ogni 2 cm
Height adjustment every 2 cm
Réglage hauteur tous les 2 cm
Höhenverstellung alle 2 cm
Ajuste de altura cada 2 cm

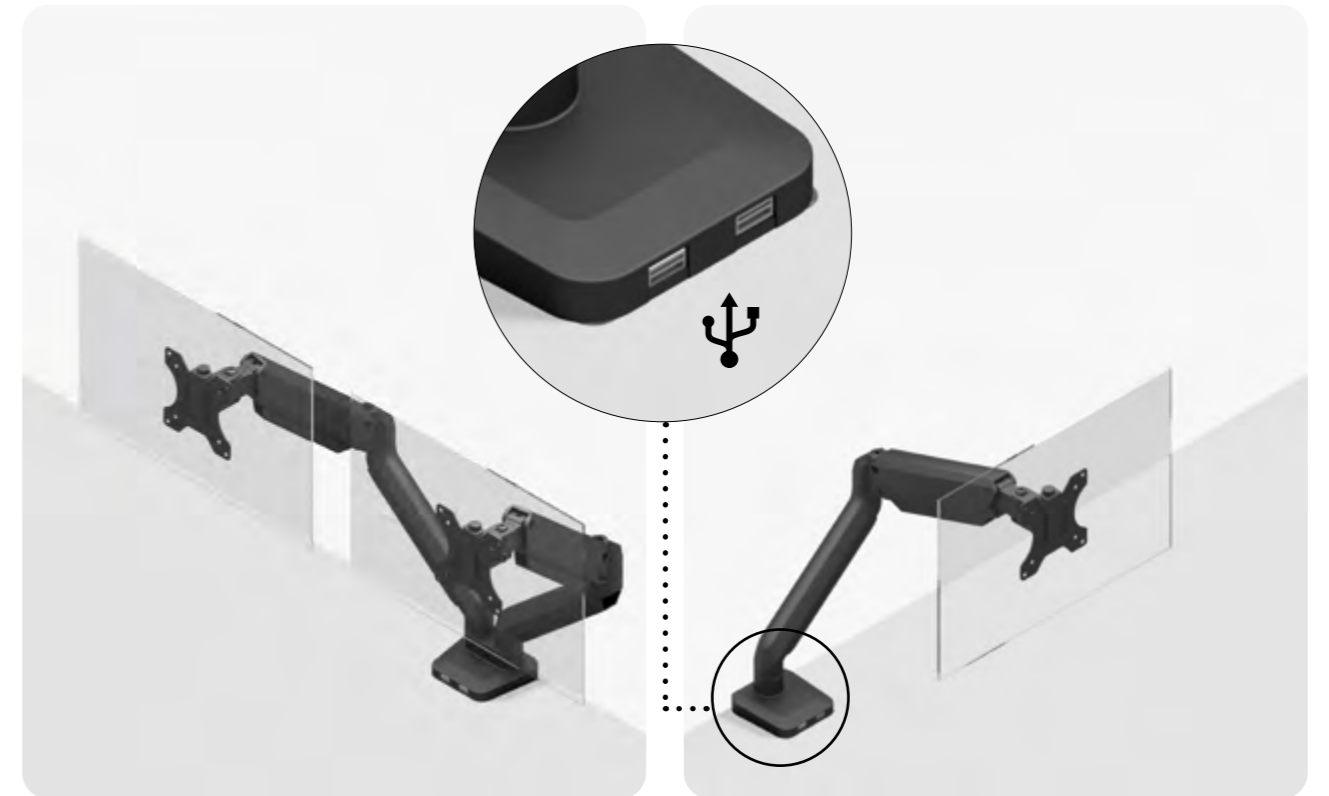

ø 8 cm
h 10 cm



ø 27 cm
h 40 cm





électrification au-dessus du plateau



plastica, plastic, plastique,
Plastick, plàstico



plastica, plastic, plastique,
Plastick, plàstico
laccato opaco, lacquered matt, laqué mat
matt lackiert, lacado mate

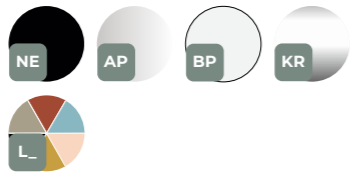

metallo, metal, métal,
metall, metal



metallo, metal, métal,
metall, metal



plastica, plastic, plastique,
Plastick, plàstico



plastica, plastic, plastique,
Plastick, plàstico



metallo, metal, métal,
metall, metal





électrification au-dessus du plateau



plastica, plastic, plastique,
Plastick, plàstico

laccato opaco, lacquered matt, laqué mat
matt lackiert, lacado mate



plastica, plastic, plastique,
Plastik, plàstico



électrification sous plateau



paniers porte-câbles



epoxia

6 avenue Charles de Gaulle
78150 Le Chesnay
+33 1 39 66 00 77
contact@epoxia.com
www.epoxia.com



Rejoignez-nous sur nos réseaux sociaux

